



**Clip-Lok SimPak<sup>®</sup>**

Automotive industry

# The Clip-Lok SimPak Group



# Company history

---

- The Clip-Lok SimPak® system was developed in Canada in 1982
- Clip-Lok SimPak® International Limited acquired the company in November 1989
- Patents and/or trade marks are now registered or pending in more than 70 countries



# A global packaging group

---

- Production, sales and marketing on four continents – North America, Europe, Africa and Asia – so we can provide service to companies across the globe.

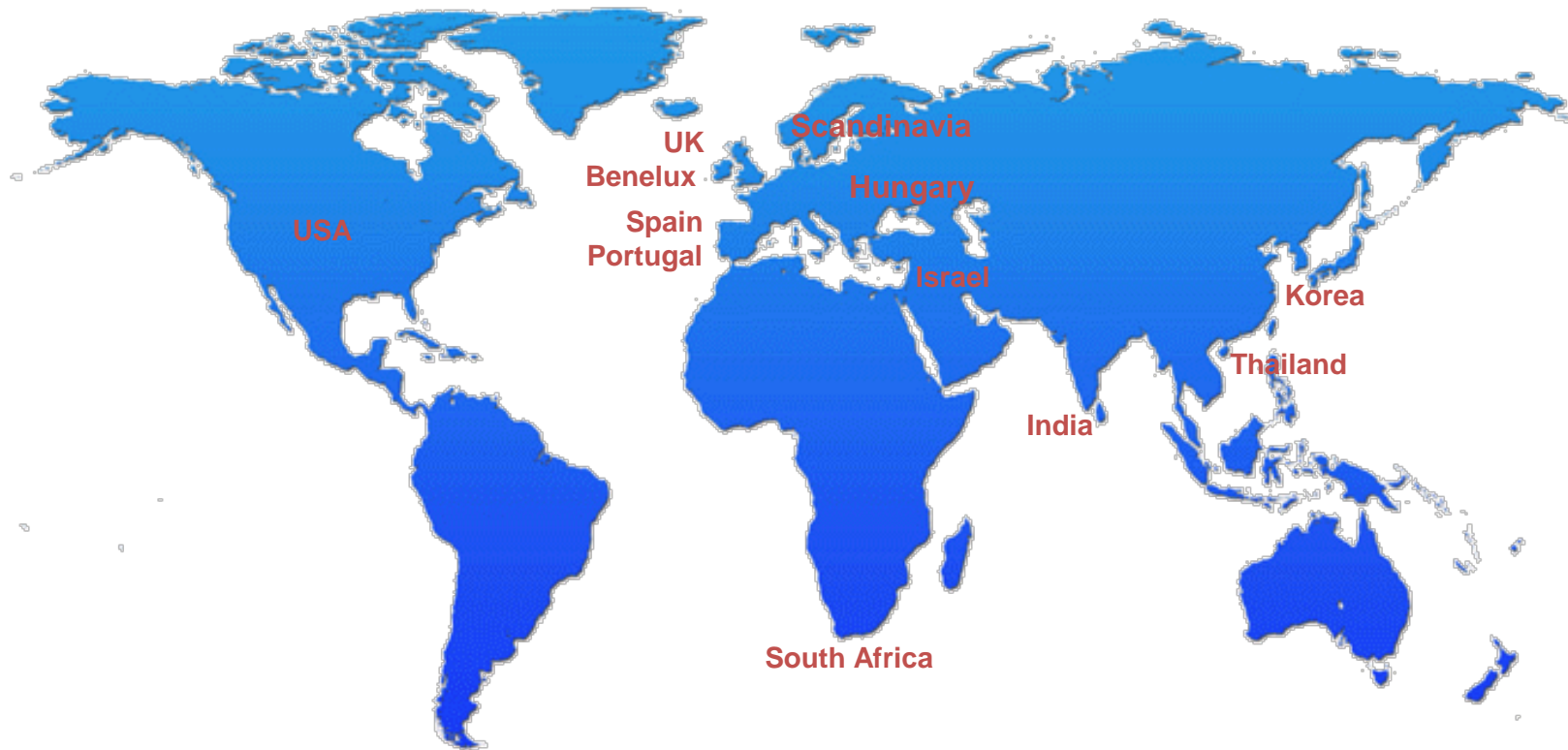

# Key segments

---

- Defense



- Automotive

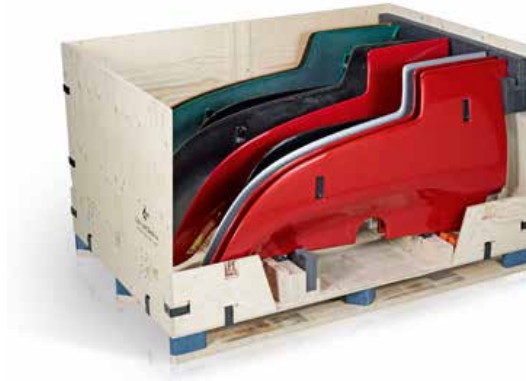

- § Aeronautics



**Why have hundreds of  
companies around the world  
chosen Clip-Lok?**



# Cost effectiveness

By choosing a Clip-Lok reusable packaging system instead of a one-way system, you can significantly reduce your costs.

- Fast return on investment - often after just three trips
- Very low maintenance costs
- Minimal return shipping and storage costs due to flat-packing
- No waste disposal costs at the end of each trip
- Custom dunnage design ensures maximum cargo protection to eliminate damage costs

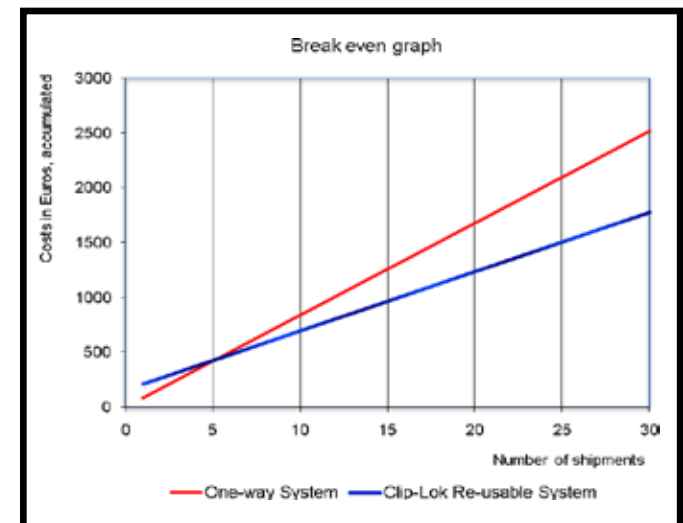
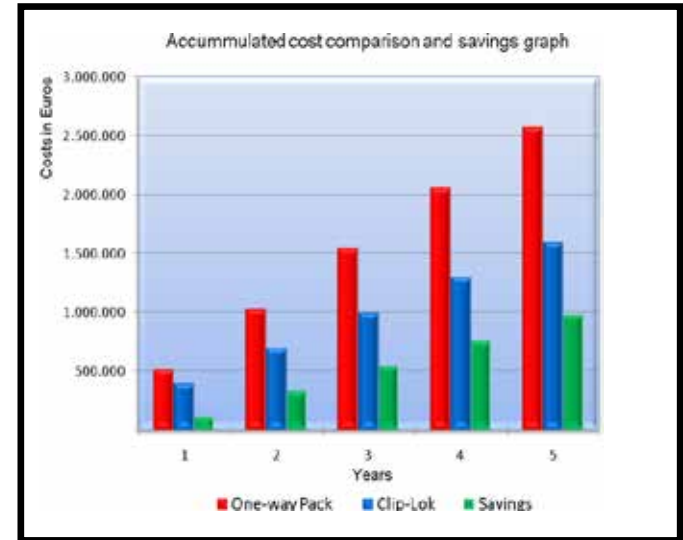



# Experience and support

---

- Over 25 years of experience
- Global support network on four continents
- International customer support at the point of dispatch and on arrival





# Quality

---

- Extensive quality testing
- Numerous certifications
- Superior reliability and strength
- Custom design



# References

---

**ArvinMeritor**



**DAIMLER**

**SAAB**



**BAE SYSTEMS**

 **AIRBUS**

GENERAL MOTORS COMPANY



**VALTRA**

**GENERAL DYNAMICS**  
*Strength On Your Side®*

# The Clip-Lok box



# Flatpackable and reusable

---

- From assembled to flatpacked in under two minutes
- All components of a flatpacked box are contained in one unit
- A flatpacked box is up to 80% smaller than an assembled box

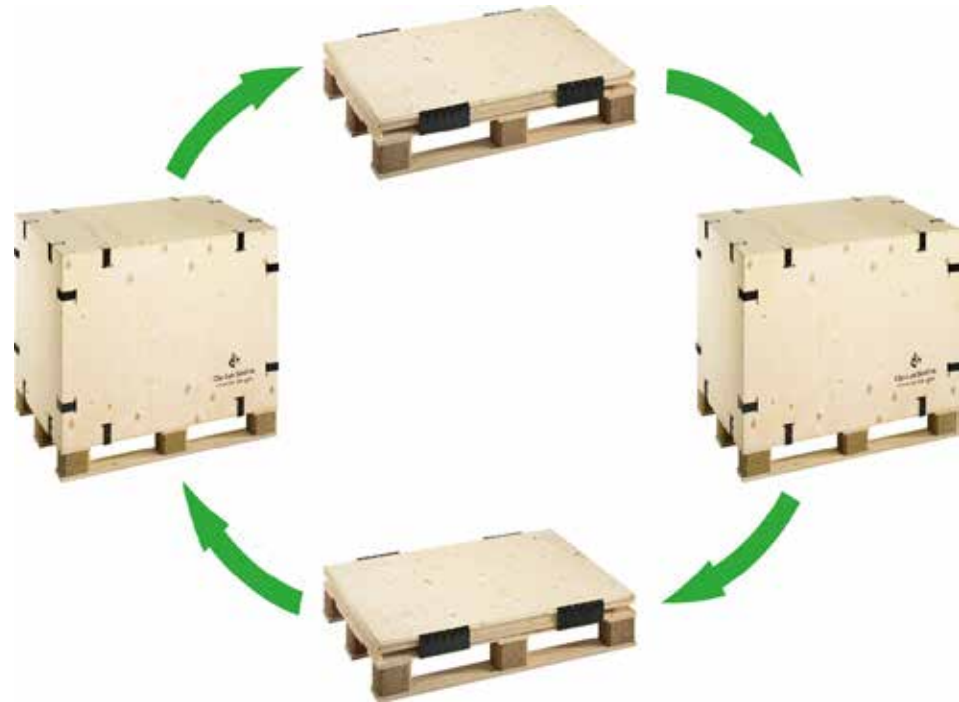

# Clip-Lok box material

---

- FCS, PEFC and ISPM15 certified plywood
- Strong and flexible
- Smooth clean surface
- Weather resistant
- Low maintenance costs - All parts can be replaced individually



# The Clip-Lok clip

---

- Made of the highest quality spring steel
- 100% elastic behavior
- Tensile strength of up to 11,000 kg
- Surface protected with a high quality coating
- Can withstand a salt spray test for more than 250 hours
- Tested and approved down to -50°C for use in arctic climates
- Tested and approved for other extreme weather conditions





# Custom design

---

Our experienced design teams will cooperate with you to meet your specific needs, including:

- Weight, volume and fragility of the product
- Loading plan
- Mode and distance of transport
- Stacking requirements
- Inner shelving and other special dunnage

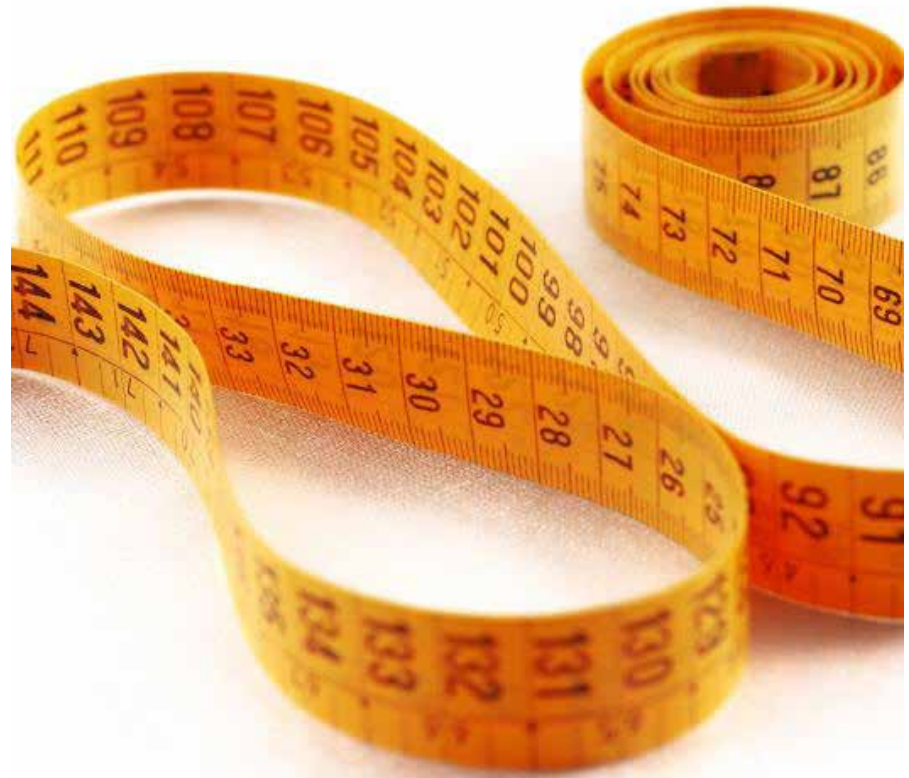



# Ergonomic design

---

- Clip-Lok boxes are designed to improve working positions
- Ergonomic and easy handling
- Easy access to items

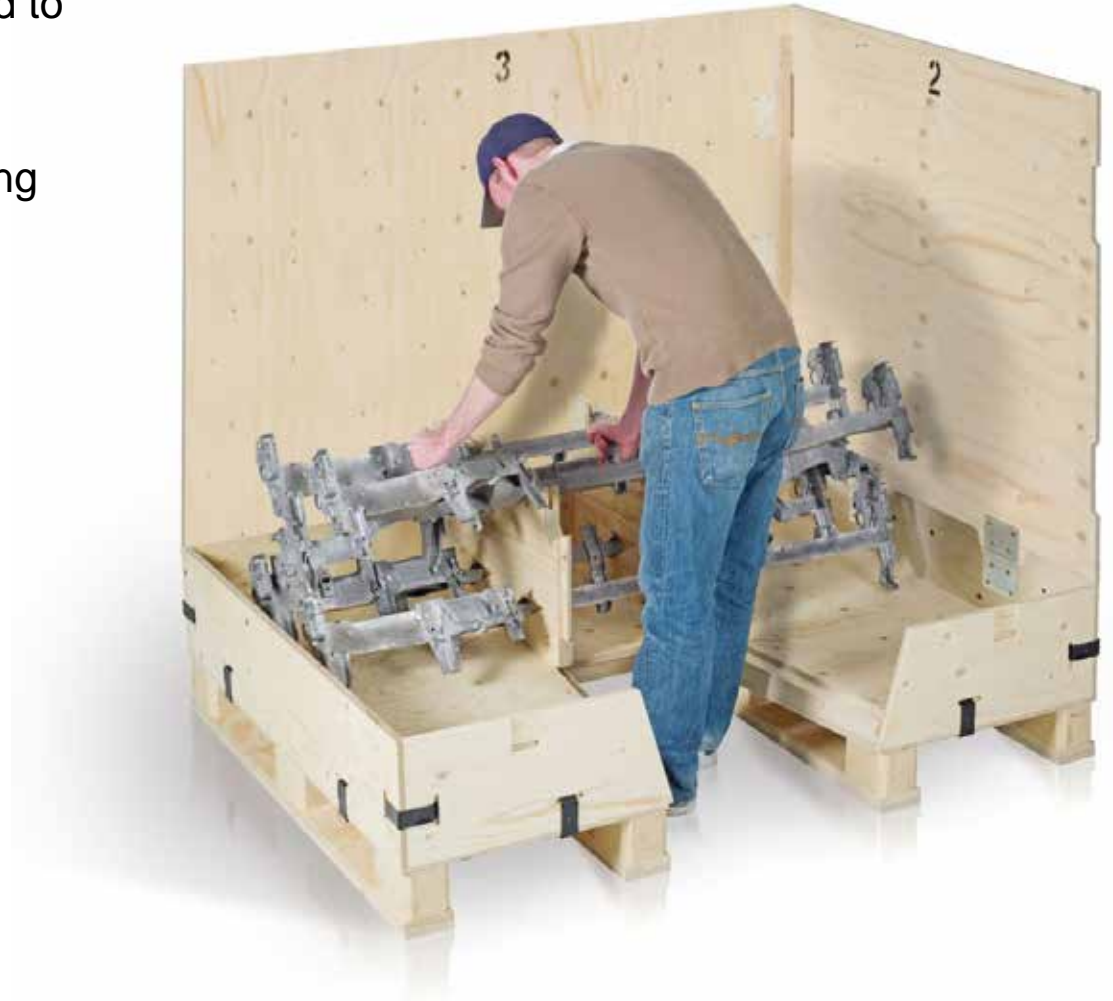

# Environment

---

- Less environmental impact than that of comparative one-way packaging
- Made of FSC, PEFC and ISPM15 certified wood
- Non-toxic glue
- Recyclable materials
- Durability, reusability and flatpack-ability reduces costs and pollution



# Tests

---

Clip-Lok boxes have been successfully tested by official test institutes around the world. Tests include:

- Pressure of up to 15 tons
- Transport of 1,000 liters liquid
- Stacking up to ten high when loaded
- Transport of hazardous goods
- Vibration durability
- Drop durability
- Weather resistance
- Impact durability



# Transport

---

Custom box size can be optimized for transport by:

- Air
- Sea
- Rail
- Road

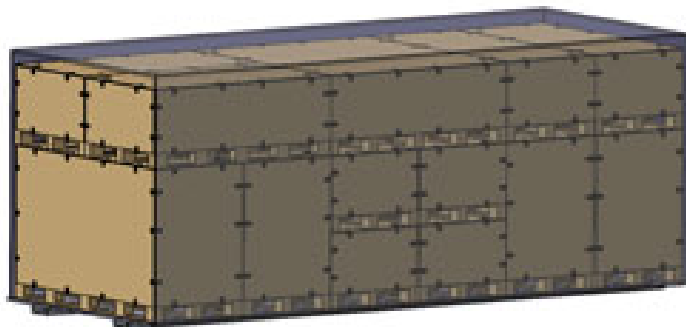



# Storage and handling

- Assembled and dismantled by one person in just a few minutes
- Loaded boxes can be stacked without racking
- Empty boxes can be collapsed, flatpacked and stacked, saving up to 80% space and saving costs
- The boxes can be a part of the production line, optimizing the work flow and saving time



# The Clip-Lok 2P box



# Advantages of the 2P box

- Only two loose parts – lid and front panel
- Hinged panels and clips
- Dunnage folds into the box when flatpacked
- Fast and easy handling
- Designed for Lean manufacturing, in-sequence delivery and JIT

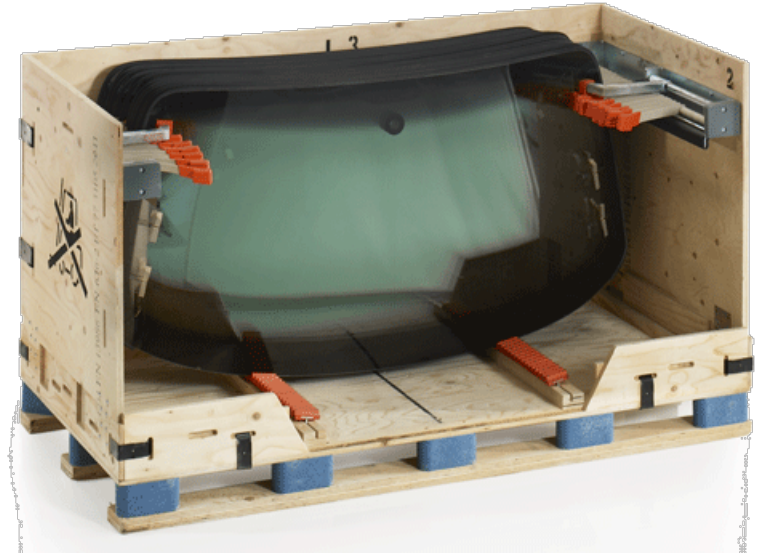



# Heavy and bulky loads

- The 2P box can be optimized for heavy and bulky parts
- Dunnage secures the parts for safe transport and easy handling
- Designed for easy access to large parts
- The loaded box becomes a part of the production line

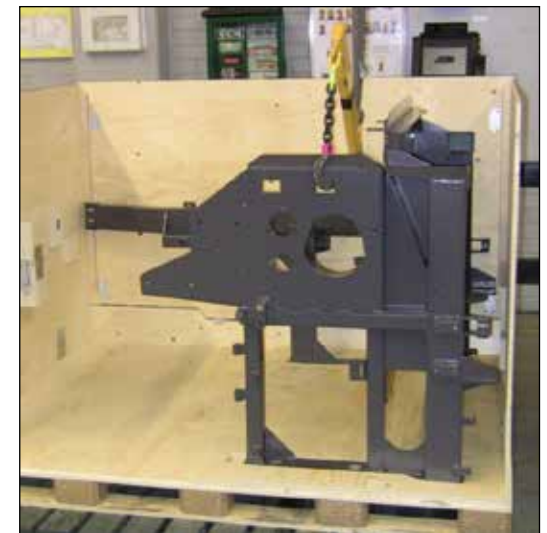

# Extra large cargo

---

- A unique hinge system allows even very large boxes to be folded down to pallet size
- One person can build-up or collapse the box in under two minutes



# Lean manufacturing

- Easily integrated into Lean manufacturing
- Designed to optimize production flow
- No need for extra packaging
- Easy handling for one person





# Auto exterior parts

---

- Parts are safely secured during transport
- Dense and protective packaging
- Easy and ergonomic access to parts
- Custom 2P box design according to the items to be transported

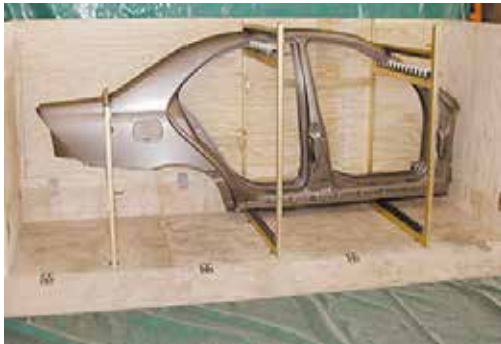

# Assembling the 2P box

---

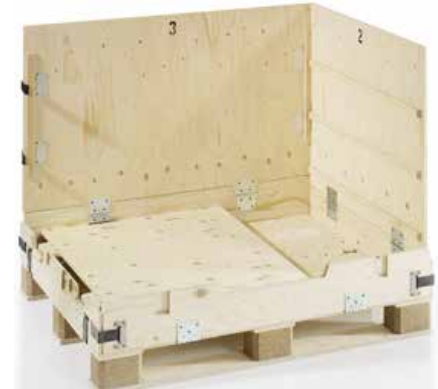

# The Clip-Lok Standard box



# Auto interior parts

---

- Safely packed to protect surfaces
- Custom dunnage design optimizes space usage
- Easy access to the parts





# Auto exterior parts

---

- Ideal for large parts such as fenders, bumpers and front grills
- Optimum space usage and full protection
- Easy loading and unloading



# Various auto parts

---

- Maximum packing density
- Easy access and handling
- The parts can be placed in several layers



# Powertrains

- Full access from all sides
- Large parts can be loaded with, for example, a crane
- The box can be built up around large heavy parts such as powertrains
- Easy to assemble when loaded



# Assembling the Standard box

---





# Dunnage



# Clip-Lok dunnage

---

- Custom designed for each assignment
- Ensures safe transport of any type of item including:
  - Sensitive electronics
  - Large glass panels
  - Heavy and bulky engine parts
- High packing density – optimized space usage within the box
- Double function dunnage for Lean manufacturing



# Dunnage materials

---

- Wide range of dunnage materials including plywood, steel, plastic, PUR and foam
- Combinations of various materials
- Chosen according to the items to be transported and the means of transport





# Integrated dunnage

---

- No loose parts
- Reduced pack and unpack times
- All parts are contained in the flat-packed box



# Other dunnage solutions

---

- Self-supported construction
- Supportive blocks
- Loose dunnage
- Shelving



# Soft-Rack dunnage

---

- Optimizes packing
- No need for extra packaging
- 2P box dunnage folds into the box when it is flatpacked
- Easy access and handling



# Engineering and service





# 3D integrated development

---

- The box design is simulated in a 3D program such as CATIA
- Allows us to determine packing density without using physical parts
- Allows fast handling of inquiries
- Based on the simulation and acquired knowledge, a prototype can be ordered for testing

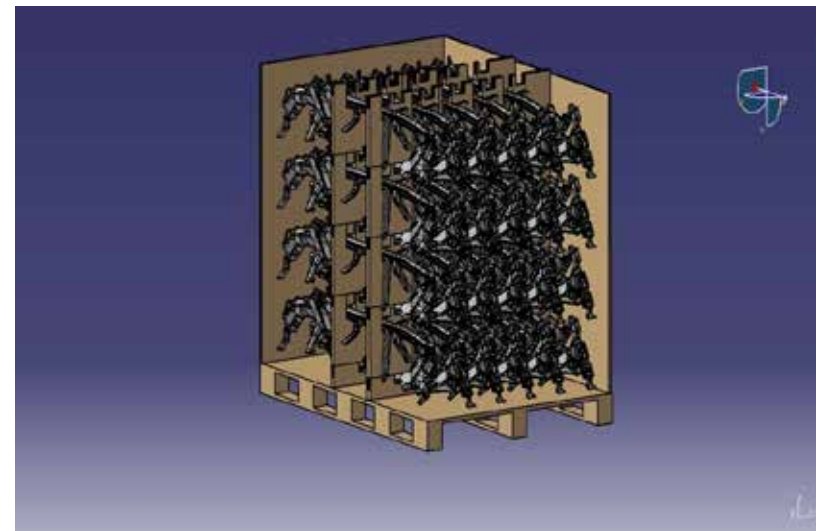
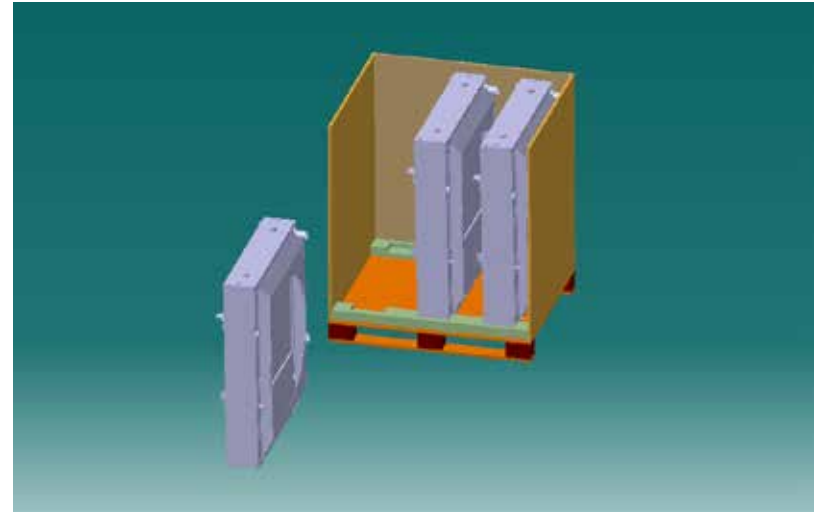



# Pack plans

---

- Pack plans can be provided upon request
- Boxes can be designed to match all kinds of transport methods

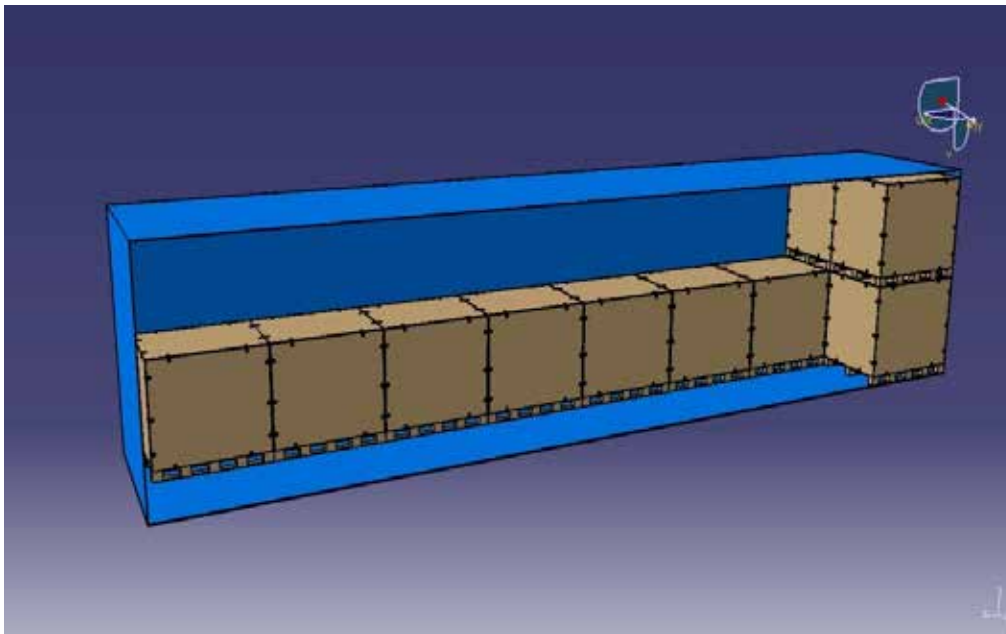

|      |      |     |
|------|------|-----|
| Nr 1 | Nr 1 | Nr1 |
| Nr 1 | Nr 2 |     |
| Nr 3 |      |     |
| Nr 4 |      |     |
| Nr 1 | Nr 1 | Nr1 |

# Feasibility study

Clip-Lok is able to calculate:

- Your cost savings when using the reusable Clip-Lok system instead of one-way boxes
- The possibilities to increase the numbers of parts and boxes per shipment
- Potential cost savings when optimum dunnage is designed

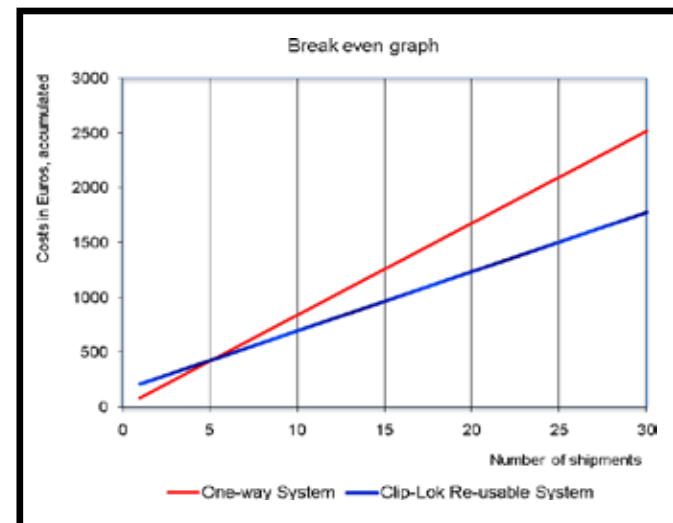
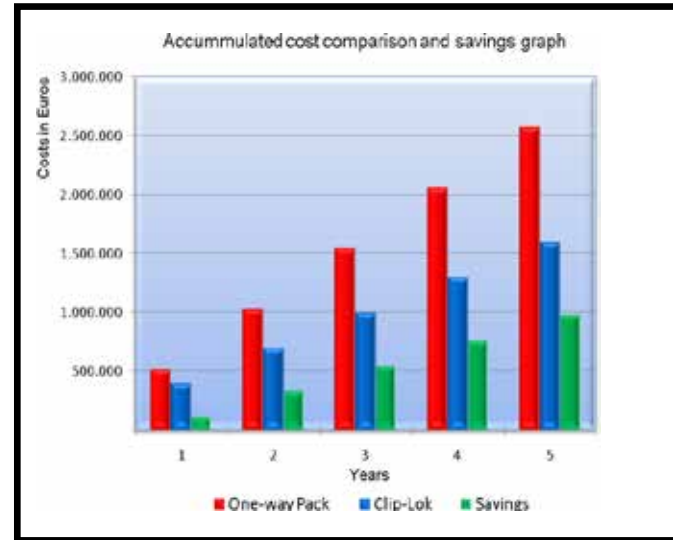

# Clip-Lok packaging guarantee

Cost effectiveness



Experience and support



Quality



# How may we help you?





**Clip-Lok SimPak<sup>®</sup>**